

General Specifications

Model VJRK Limit Alarm (RTD Input Type)

JUXTA

GS 77J01R21-01E

General

This plug-in type Limit Alarm for RTD input receives RTD signal.

- Each parameter setting can be changed using a PC (VJ77 PC-based Parameters Setting Tool) or the Handy Terminal (JHT200).

Model and Suffix Codes

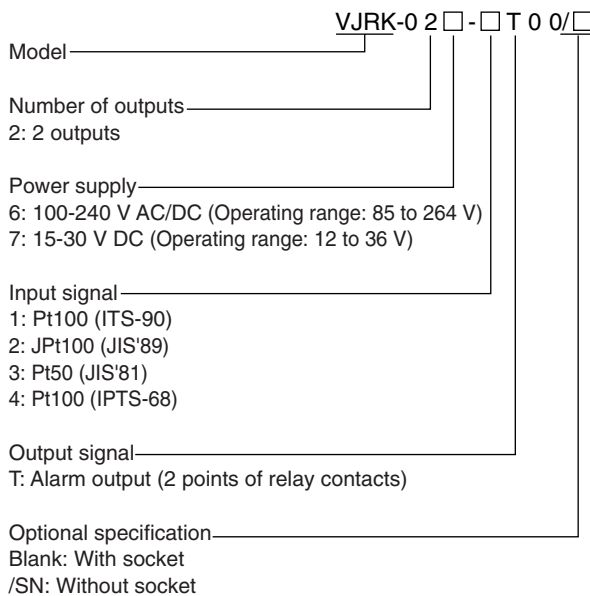

Ordering Information

Specify the model and suffix codes at the time of order. If the input range and burnout are specified with the order, the specified values will be assigned before shipment.

For other setting items, the initial values shown below are to be assigned.

- Model and suffix codes: e.g. VJRK-026-1T00
- Input range: 0 to 100°C
- Burnout: UP

Initial Values (Factory-set Values)

The initial values (factory-set values) are as follows.

- Input range: 0 to 100°C
- Burnout: UP
- Direction of alarm action: High-limit alarm (alarm 1), low-limit alarm (alarm 2)
- Direction of relay action: De-energized under normal condition (alarm 1 and alarm 2).
- Alarm setting: The value equivalent to 100% of input range (alarm 1), the value equivalent to 0% of input range (alarm 2)

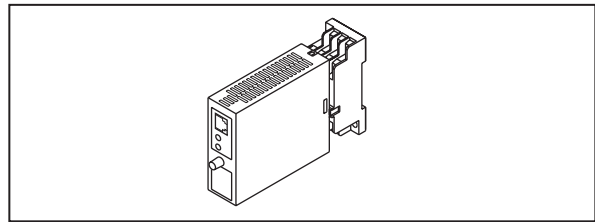

- Hysteresis: The value equivalent to 3% of input range (alarm 1 and alarm 2)
- Alarm ON delay: 0 second (alarm 1 and alarm 2)
- Alarm OFF delay: 0 second (alarm 1 and alarm 2)

Input Specifications

Input type: IEC/JIS-standard RTD

Pt100 (ITS-90), JPt100 (JIS'89), Pt50 (JIS'81) and Pt100 (IPTS-68)

Pt100 (ITS-90): $R_0=100 \Omega$, $R_{100}/R_0=1.3851$

JPt100 (JIS'89): $R_0=100 \Omega$, $R_{100}/R_0=1.3916$

Pt100 (IPTS-68): $R_0=100 \Omega$, $R_{100}/R_0=1.3850$

Input range:

Input type	Guaranteed range
Pt100 (ITS-90)	-200 to 660°C
Pt100 (IPTS-68)	-200 to 660°C
JPt100 (JIS'89)	-200 to 510°C
Pt50 (JIS'81)	-200 to 649°C

Measuring span: 10°C or more

Input resistance: 1 M Ω (during power on), 4 k Ω (during power off)

Allowable leadwire resistance: [Input span (°C) \times 0.4 Ω] or 10 Ω per leadwire, equal or less than whichever is smaller. (Make the resistance of each wire the same.)

However, when used with BARD-700, this value can be added to the BARD internal resistance.

Detective current: Approx. 0.5 mA

Maximum allowable voltage: ± 4 V DC

Output Specifications

Signal type: Relay contact

Output signal: NO contact output (contact turns on when energized), 2 points

Contact rating: 120 V AC/1 A, 220 V AC/0.5 A (resistance load)

30 V DC/1 A, 120 V DC/0.1 A (resistance load)

Direction of alarm action: High-limit alarm or low-limit alarm

Direction of relay action: Energized or de-energized under normal condition

Alarm setting range: 0 to 100% of input range
Setting resolution: 0.1°C, with four significant digits

Hysteresis setting range: 0 to 100% of input range
Setting resolution: 0.1°C, with four significant digits

Alarm ON delay: Condition monitoring time from the establishment of alarm conditions to its output.
(For example, when an alarm ON delay is set to 1 second, alarm output is generated if alarm status continues for 1 second or more after the input value exceeds the alarm setpoint.)

Setting range: 0 to 999 seconds
Setting resolution: 1 second (However, about 0.2 second is to be added to the set time to prevent wrong operation.)

Alarm OFF delay: Condition monitoring time from the establishment of return-to-normal conditions to its output.
(For example, when an alarm OFF delay is set to 2 seconds, alarm output is released if normal condition continues for 2 seconds or more after the input value has returned to normal from the alarm status.)

Setting range: 0 to 999 seconds
Setting resolution: 1 second (However, about 0.2 second is to be added to the set time to prevent wrong operation.)

Indication of alarm action: The alarm indicator lamp (LED) on the front panel lights up if an alarm occurs. (2 lamps)

■ Items Available to Be Set

The following items can be set using a PC (VJ77 PC-based Parameters Setting Tool) or the Handy Terminal (JHT200):

Input type, input range, burnout, direction of alarm action, direction of relay action, alarm setting, hysteresis, alarm ON delay and alarm OFF delay

■ Standard Performance

Accuracy rating: $\pm 0.1\%$ of span
However, the accuracy is limited in the following cases.

When a span is less than 130 Ω in an input range of 0 to 520 Ω (H range) based on the reference resistance table:
Accuracy (%) = $\pm 0.1 (\%) \times 130 (\Omega) / \text{input span } (\Omega)$

When a span is less than 38.6 Ω in an input range of 0 to 520 Ω (M range) based on the reference resistance table:
Accuracy (%) = $\pm 0.1 (\%) \times 38.6 (\Omega) / \text{input span } (\Omega)$

Response speed: 450 ms (Time to alarm output when the input change is 10 to 90% and alarm setpoint is 50%. When the alarm delay setting and hysteresis are minimum.)

Burnout: UP, DOWN or OFF
Burnout time: Within 60 seconds

Effect of power supply voltage fluctuations: $\pm 0.1\%$ of span or less for the fluctuations within the allowable range of each power supply voltage specification

Effect of ambient temperature change: $\pm 0.2\%$ of span or less for a temperature change of 10°C

Effects of leadwire resistance change: $\pm 0.2^\circ\text{C}$ or less for a change of 10 Ω /leadwire

■ Power Supply and Isolation

Power supply rated voltage:
100-240 V AC/DC \approx 50/60 Hz or
15-30 V DC \approx

Power supply input voltage: 100-240 V AC/DC \approx
(-15, +10%) 50/60 Hz or
15-30 V DC \approx ($\pm 20\%$)

Power consumption: 24 V DC 1.9 W, 110 V DC 1.9 W
100 V AC 4.1 VA, 200 V AC 5.1 VA

Insulation resistance: 100 M Ω /500 V DC between input, output 1, output 2, power supply and grounding terminals mutually.

Withstand voltage: 2000 V AC/minute between input, (output 1, output 2), power supply and grounding terminals mutually.
1000 V AC/minute between output 1 and output 2 terminals.

■ Environmental Conditions

Operating temperature range: 0 to 50°C
Operating humidity range: 5 to 90% RH (no condensation)

Operating conditions: Avoid installation in such environments as corrosive gas like sulfide hydrogen, dust, sea breeze and direct sunlight.

Installation altitude: 2000 m or less above sea level.

■ Mounting and Dimensions

Construction: Compact plug-in type
Material: Modified polyphenylene oxide resin (casing)
Mounting method: Wall or DIN rail mounting, or mounting using VJ mounting base
Connection method: M3 screw terminal
External dimensions: 29.5 (W) \times 76 (H) \times 124.5(D) mm (including a socket)
Weight: Approx. 170 g

■ Accessories

Tag number label: 1 sheet
Range label: 1 sheet

Terminal Assignments

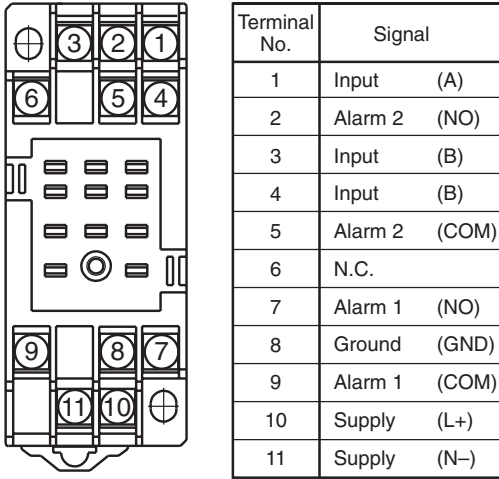

Block Diagram

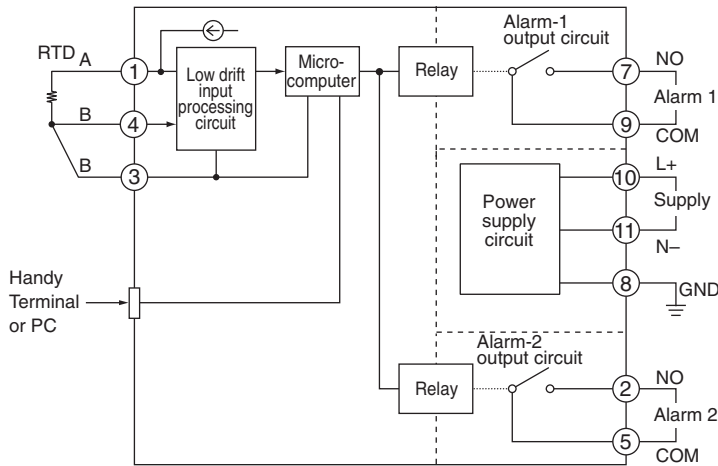

Note: Make the wiring resistance of the input terminals 1 and 3 the same.

External Dimensions

